



# FITTING INSTRUCTIONS

Part Number: **3424050**

Product Description: **COMBINATION BAR SUITS MY19 SUZUKI JIMNY**

Suited to vehicle/s: **Jan 2019 on Suzuki Jimny**

Optional Kits: **3500720** Winch Install Kit  
**3500680** Fog Lamp Housing Clear Lens Kit

## WARNING

### REGARDING VEHICLES EQUIPPED WITH SRS AIRBAG:

When installed in accordance with these instructions, the front protection bar does not affect operation of the SRS airbag.

### ALSO, NOTE THE FOLLOWING:

- ◆ This product must be installed exactly as per these instructions using only the hardware supplied.
- ◆ In the event of damage to any bull bar component, contact your nearest authorised ARB stockist. Repairs or modifications to the impact absorption system must not be attempted.
- ◆ Do not use this product for any vehicle make or model, other than those specified by ARB.
- ◆ Do not remove labels from this bull bar.
- ◆ This product or its fixing must not be modified in any way.
- ◆ The installation of this product may require the use of specialized tools and/or techniques
- ◆ It is recommended that this product is only installed by trained personnel.
- ◆ These instructions are correct as at the publication date. ARB Corporation Ltd. cannot be held responsible for the impact of any changes subsequently made by the vehicle manufacturer.
- ◆ During installation, it is the duty of the installer to check correct operation/clearances of all components
- ◆ Work safely at all times.
- ◆ Unless otherwise instructed, tighten fasteners to specified torque.

## **ARB 4x4 ACCESSORIES**

### Corporate Head Office

42-44 Garden St  
Kilsyth, Victoria  
AUSTRALIA 3137

Tel: +61 (3) 9761 6622  
Fax: +61 (3) 9761 6807

Australian enquiries  
North & South American enquiries  
Other international enquiries

sales@arb.com.au  
sales@arbusa.com  
exports@arb.com.au

**www.arb.com.au**

# GENERAL CARE AND MAINTENANCE

By choosing an ARB Bar, you have bought a product that is one of the most sought after 4WD products in the world. Your bar is a properly engineered, reliable, quality accessory that represents excellent value. To keep your bar in original condition it is important to care and maintain it following these recommendations:



- Prior to exposure to the weather your bar should be treated to a Carnauba based polish on all exposed surfaces. It is recommended that this is performed on a six monthly basis or following exposure to salt, mud, sand or other contaminants.
- As part of any Pre Trip Preparation, or on an annual basis, it is recommended that a thorough visual inspection of the bar is carried out, making sure that all bolts and other components are torqued to the correct specification. Also check that all wiring sheaths, connectors, and fittings are free of damage. Replace any components as necessary. This service can be performed by your local authorized ARB Stockist.

## FITTING REQUIREMENTS

### REQUIRED TOOLS FOR FITMENT OF PRODUCT:

METRIC SOCKET SET	METRIC RING AND OPEN ENDED SPANNER SET
ELECTRIC DRILL 13 MM CAPACITY	8, 10, 10.5 & 13 mm DRILL BITS
TORQUE WRENCHES 9-96Nm	PHILLIPS AND FLAT BLADE SCREW DRIVER SETS
FELT TIP MARKER PEN WHITE	HACKSAW BLADE
SATIN BLACK SPRAY PAINT	JIG SAW OR MULTI-TOOL WITH BLADE SUITABLE FOR PLASTIC
50 mm WIDE MASKING TAPE	

### HAVE AVAILABLE THESE SAFETY ITEMS WHEN FITTING PRODUCT:

Protective eyewear 	Hearing protection 
--	--

**NOTE: 'WARNING' notes in the fitting procedure relate to OHS situations, where to avoid a potentially hazardous situation it is suggested that protective safety gear be worn or a safe work procedure be employed. If these notes and warnings are not heeded, injury may result.**

### FASTENER TORQUE SETTINGS:

SIZE	Torque Nm	Torque lbft
M6	9	7
M8	22	16
M10 / 3/8" UNC	44	32
M12 x 1.75	77	57
M12 x 1.25	96	71

**PARTS LISTING**

<b>APPLICATION.</b>	<b>PART NO.</b>	<b>DESCRIPTION</b>	<b>QTY</b>
<b>FIT MOUNT BRACKETS TO CHASSIS</b>	3752141R	BRKT CHASSIS JIMNY RH	1
	3752141L	BRKT CHASSIS JIMNY LH	1
	3752139R	BRKT MOUNT JIMNY RH	1
	3752139L	BRKT MOUNT JIMNY LH	1
	3752362	BRKT CRADLE JIMNY	1
	4721687	TUBE CRUSH	4
	6151614	BOLT M10 X 1.5 X 70 GD 8.8 TZP	4
	4581040	WASHER FLAT M10 X 25 TZP	4
	6151321	NUT FLANGE M10 X 1.5 TZP	8
	6151357	SCREW SEMS M10 X 1.5 X 30 TZP	4
	6151021	BOLT M8 X 1.25 X 20 GD 8.8 TZP	8
	4581044	WASHER FLAT M6 TZP	8
	6151132	NUT FLANGE M8 X 1.25 TZP	8
<b>FIT MOULDINGS AND LIGHTS</b>	3163197	KIT SURROUND ARB FOGLIGHT SUITS TOYOTA	1
	3500880	GRILLE SPLIT PAN KIT	1
	6821287	LAMP LED INDICATOR CLEARANCE KIT	1
	3163091	PLUG BLANKING 17.4MM	2
	3752142	BRKT GRILLE JIMNY	2
	6151213	BOLT M6 X 1 X 20 GD 8.8 TZP BLACK	8
	4584295	WASHER FLAT M6 X 12 TZP BLACK	8
	6151128	NUT FLANGE M6 TZP	8
	3752138R	BRKT FOG JIMNY RH	1
	3752138L	BRKT FOG JIMNY LH	1
	6821116	GROMMET NYLON SQUARE SNAP IN TYPE	4
<b>FIT LICENCE PLATE BRACKET</b>	6151213	BOLT M6 x 1.0 x 20 Gd8.8 BZ	3
	4584295	WASHER FLAT M6 X 12 X 1.3 BLK ZN	3
	6151128	NUT FLANGE M6 x 1.0 BZP	3
	6821189	GROMMET RND FC 1500 080 090	2
	3759488	BRACKET LIC PLATE FIXED LARGE RAD	1
	6151384	SCREW ST PHDCOL PH 5.2 X 16 TBZP480	2
<b>MISC</b>	6523170	PRESS FORM WINCH COVER PANEL TEXTURED BLACK	1
	180302	CABLE TIE 4.8 X 180 MM BLACK	9
	4584295	WASHER FLAT M6 X 12 X 1.3 BLK ZN	4
	6151128	NUT FLANGE M6 x 1.0 BZP	4
	6151213	BOLT M6 x 1.0 x 20 Gd8.8 BZ	4
<b>FIT BAR TO MOUNT</b>	6151357	SCREW SEMS M10 X 1.5 X 30 TZP	10
	6151321	NUT FLANGE M10 X 1.5 TZP	10
<b>FIT UNDER PANELS TO BAR</b>	6523279	PANEL SPLASH JIMNY	1
	6151234	BOLT M8 X 1.25 X 25 GD8.8 TZP BLACK	4
	4581307	WASHER M8 X 20 TZP BLACK	4
	6151132	NUT FLANGE M8 TZP	4
	6151213	BOLT M6 X 1 X 20 GD8.8 BZ	3
	4584295	WASHER FLAT M6 X 12 TZP BLACK	3

## FITTING PROCEDURE



1. Remove licence plate



2. Remove plastic clips securing inner guard to bumper.
3. Remove steel screws securing inner guard to bumper refer arrow. Retain these screws.



4. Remove lower screws securing inner guard to bumper.

## FITTING PROCEDURE

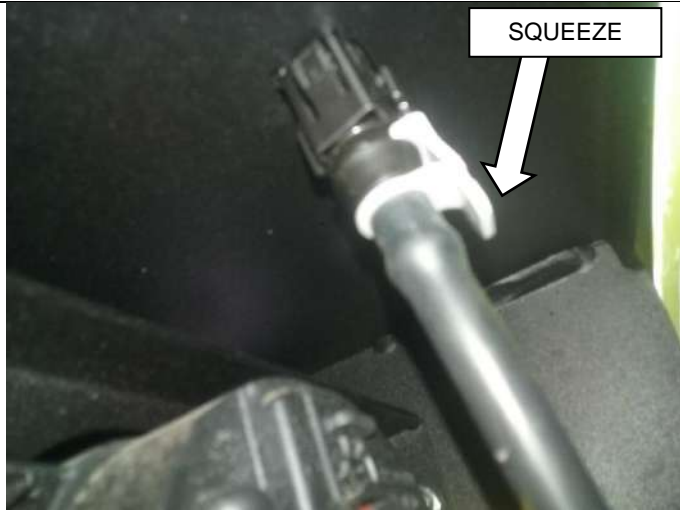

5. Move the inner guard away and locate headlight washers. Squeeze the grey tab shown by arrow and pull down on hose. Repeat for opposite side.



6. Locate the joiner for the two headlight washers on the LH side and do the same to it's connection. The headlight washer circuit is now disconnected from the vehicle. Un-plug the fog lights at this stage also.



7. Using a small flat screw driver place it under the lip located at the front of the housing (Arrow). Move lip out a little and pull down on the water nipple and release it from the main housing. Press two tabs in on housing and remove up from bumper. Retain all parts for later use.



8. Remove the three hex head screws from the center of the bumper.



9. Remove plastic clips from radiator support panel which secures grille to body. Retain clips.



10. Locate square shaped clips on inside of headlights. Rotate quarter turn in either direction whilst pulling out on the grille slightly.



11. Start pulling from the center of the grille and work your way out to release the press in clips. Remove plugs from indicators and place grille in a safe location.





12. As shown remove the plastic clips from the plastic grille air dam and retain.



13. Remove and retain plastic air dam.



14. Remove plastic clips securing top of bumper to vehicle body.



15. At this stage ensure the fog/DRL lights are all un-plugged.

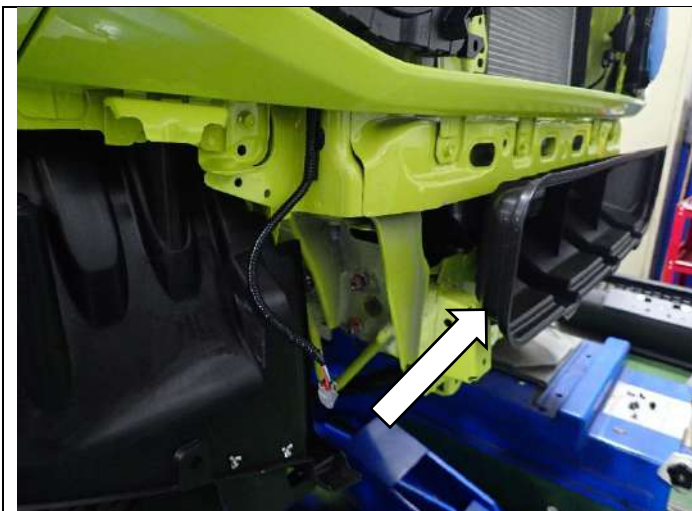

16. Carefully remove bumper. Locate lower plastic air intake. Remove and discard this item.



17. For light coloured vehicles. As shown in the image mask off the area shown. Clean beforehand. Carefully paint using satin black spray paint.



18. End result should look as shown. This area is highly visible with a bar fitted and must be painted for light coloured vehicles.

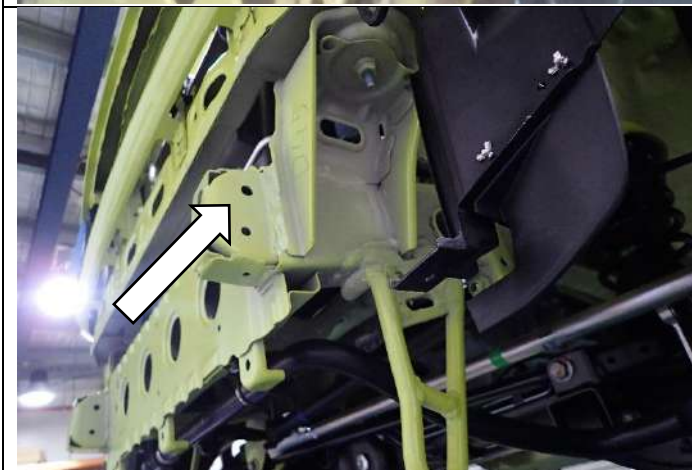

19. Locate the two outside holes on each chassis end as shown. Drill the two outside holes only using a 13mm drill bit. DO NOT GO ALL THE WAY THROUGH CHASSIS. De-burr and paint when done. Repeat for opposite side.







20. The two inside holes of the chassis must be drilled out using a 10.5mm drill bit. De-burr and paint when done. Repeat for opposite side.



21. Locate the two holes in the front crossmember as shown. Drill out to 10.5mm. De-burr and paint.



22. LH side chassis mount shown. Prepare chassis mount using two M10 x 70 bolts with M10 flat washers. Place these through the M10 holes as shown and slide the M10 crush sleeves over them.



23. Place the chassis mount onto the outside of the chassis feeding the M10 bolts through the drilled holes.



24. Place inner chassis mount over M10 bolts and loosely secure using M10 flange nuts.

25. Fit four silver M8 x 20 bolts, flat washers and flange nuts through both brackets as shown. Flange nuts to inside area.

26. Fit M10 SEMS bolt through small bracket into chassis crossmember and secure with M10 flange nut on inside.

 M10 - 44 Nm.

 M8 - 22 Nm.



27. Fit cradle bracket 3752362 to chassis crossmember and secure using M10 SEMS bolts and M10 flange nuts. Ensure the outer M8 holes sit underneath the outer chassis mounts. Do not install M8 bolts in the outer holes at this stage.

 M10 - 44 Nm.



28. Remove the fog/DRL and headlight washer system from bumper. Make sure you also remove the small loom from bumper also.



29. Install indicator and park light looms to vehicle at this stage either soldering or using scotch locks provided.

30. To gain access on the RH side remove the air intake hose as shown.

**Note: If fitting a winch proceed using fitting instructions 3789337 supplied with 3500720 winch install kit. Once the winch is fitted please continue to step 34. If no winch is being fitted continue from step 31.**

**\*\*THIS PRODUCT IS NOT DESIGNED FOR WINCHES LARGER THAN 8000LB\*\***

**\*\*ENSURE WINCH CONTROL BOXES ARE ADJUSTED ALL THE WAY FORWARD\*\***

31. Slide the winch cover panel from the bottom up until it is level with the top face of the bar.

32. Fit the winch cover panel to the bar using 4 x M6 x 20 hex bolts, flat washers and flange nuts.

**Warning: Be careful not to scratch the finish of the winch cover panel.**

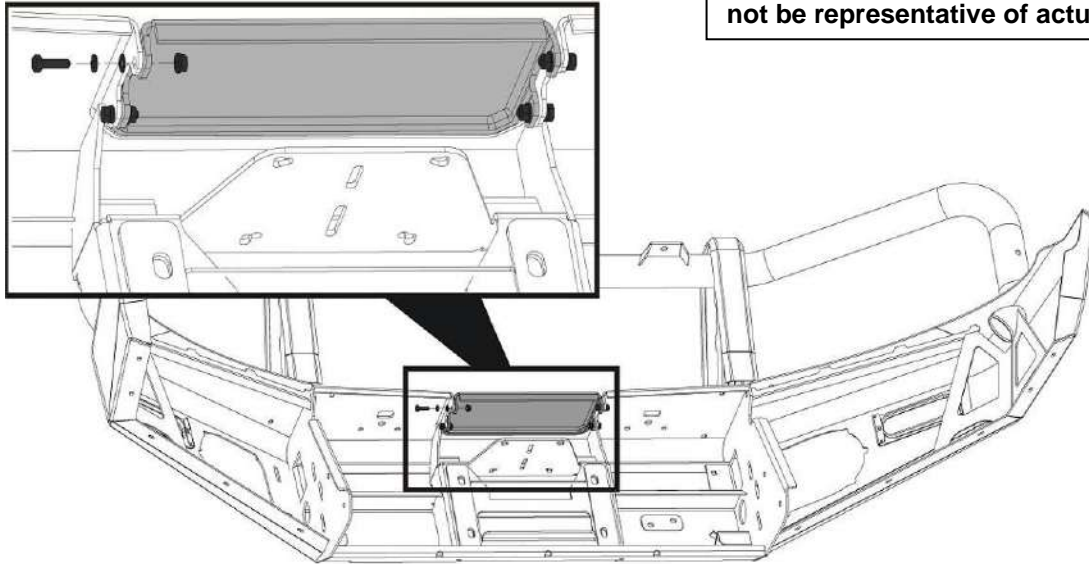

33. Fit the number plate bracket to the top face of the lower-centre pan on the bar using 3 x M6 x 20 hex bolts, flat washers and flange nuts.

**Note: If you are fitting a winch, fit the folding number plate bracket supplied in winch install kit "3500720 WINCH INSTALL KIT" – See fitting instructions 3789337**

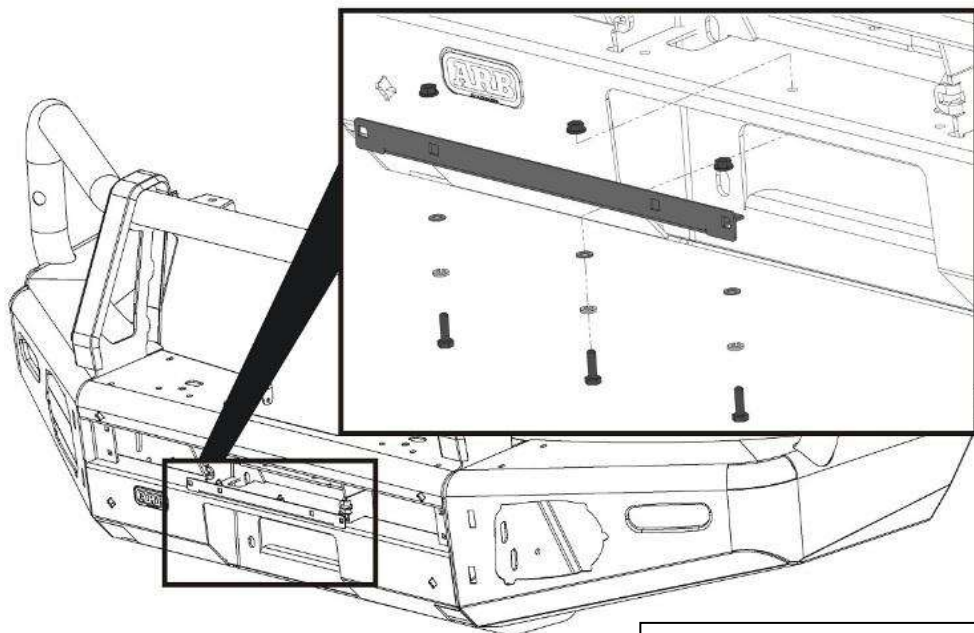

34. Layout the contents of each of the following kits ensuring the contents are kept separate from each other.

**Note: The following steps show the fitment of the plastic moulded parts. The mouldings are supplied in kits along with all fasteners required for fitment. It is important that the fasteners supplied with each kit are only used for the mouldings from the same kit.**

**The kits included in this bar kit are as follows:**

Kit No.	Description
3500880	SPLIT PAN MESH KIT
3163197	FOG SURROUND KIT

35. Mark the grille panel to be cut at 690mm overall. Measure 27mm out from each door opening frame.

**Note: When marked, double check the measurement with a measuring tool.**

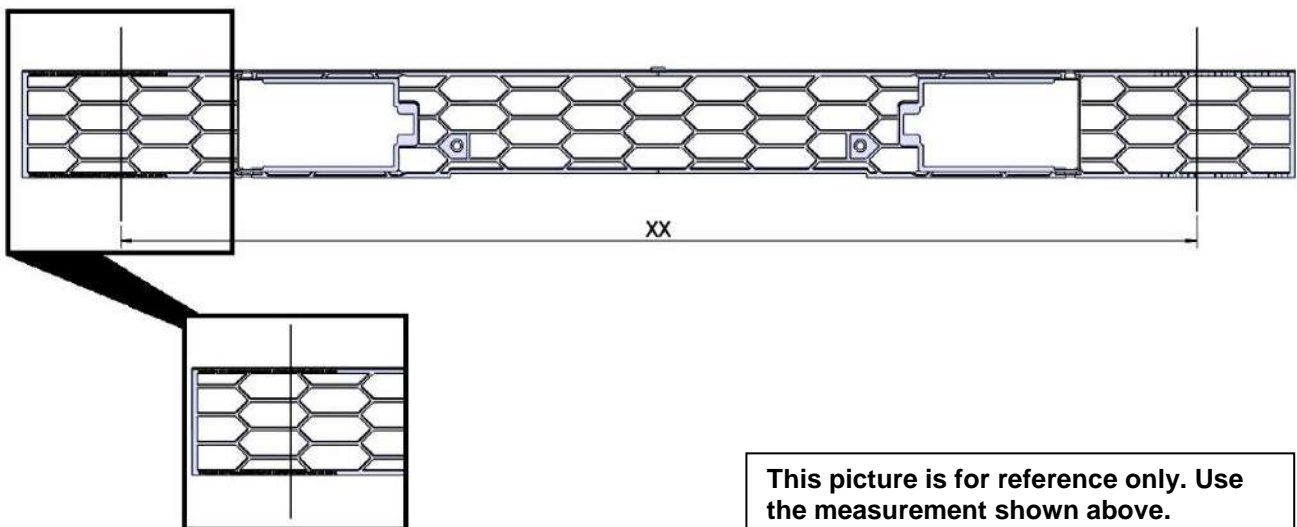

36. Use a hacksaw or similar cutting tool to carefully cut the grille panel at the positions marked in the step above.

37. Discard the off cuts and clean up the cut edges using a file or sandpaper.

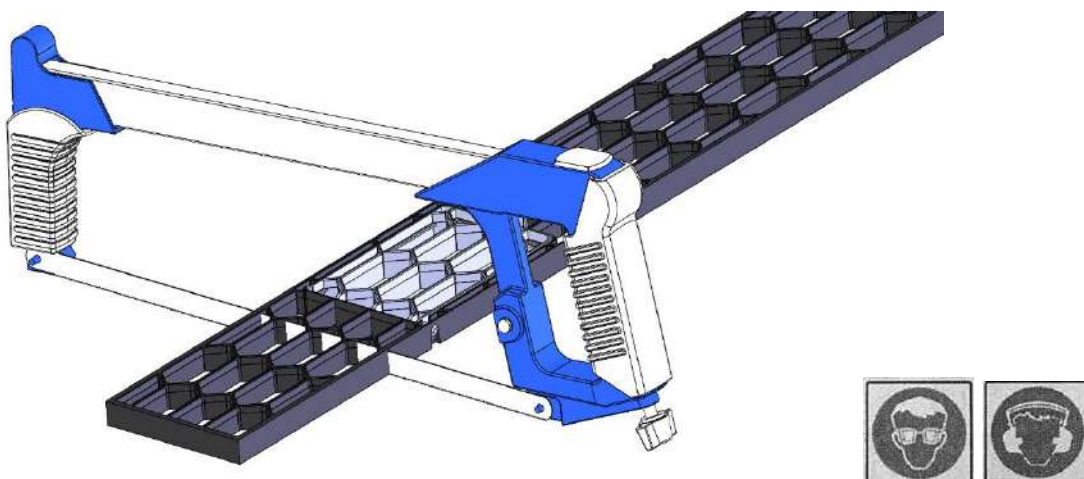

38. Insert the 2 x plastic grommets into the 2 square holes in the front face of the bar.

39. Insert the grille into the bar so that the hatches open outward (facing the front of the bar).

40. Attach the grille to the centre of the bar using the short screws into the grommets fitted above.

41. Attach the ends of the grille to the bar using 3752142 brackets, black M6 x 20 bolts, black M6 flat washers and M6 flange nuts through bracket into bar as shown.

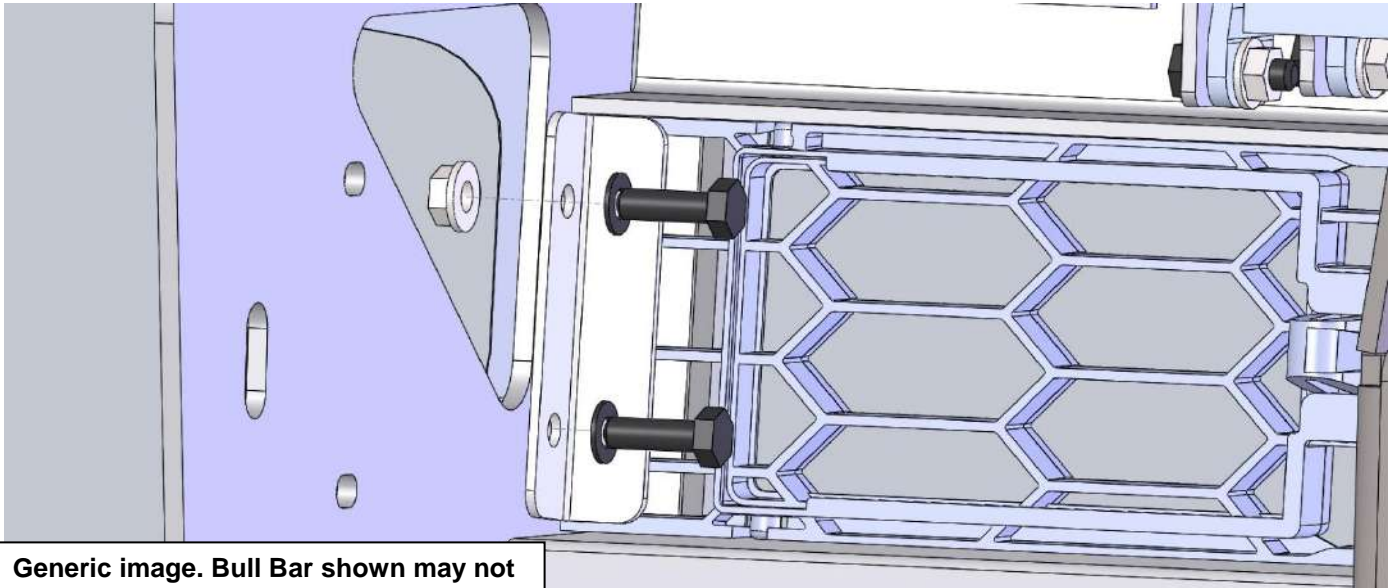

Generic image. Bull Bar shown may not be representative of actual product.



M6 - 7 Nm.

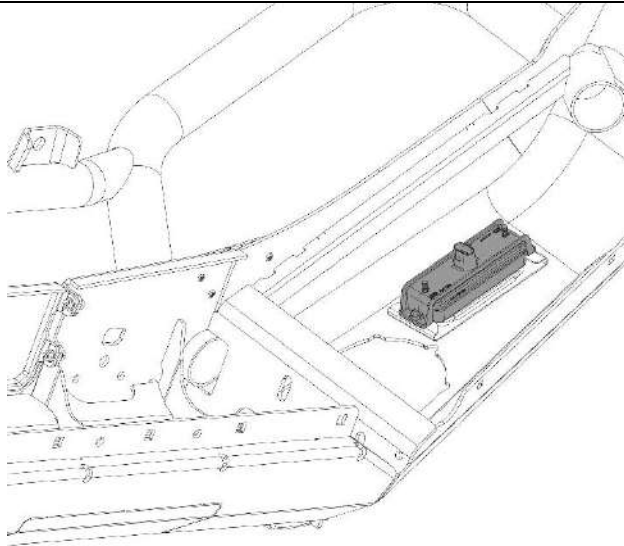

47. Fit the small plastic grommets to the bar and attach the combination LED lamps to the bar using the screws provided with the lamp kit.

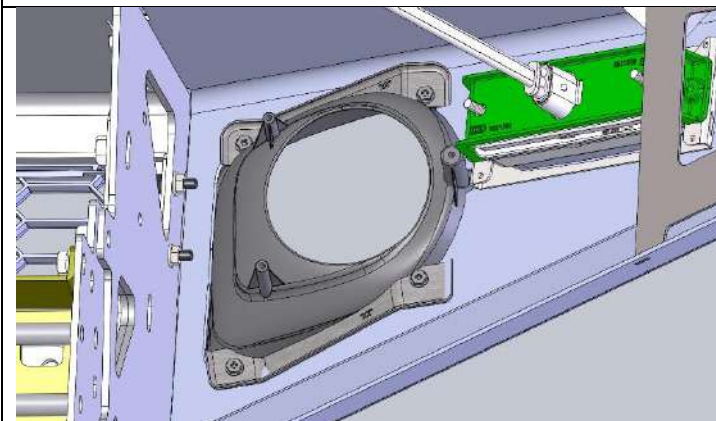

48. Install Fog light surrounds (3163197) as per instruction no. 3789800 supplied with surround kit into aperture of bull bar.

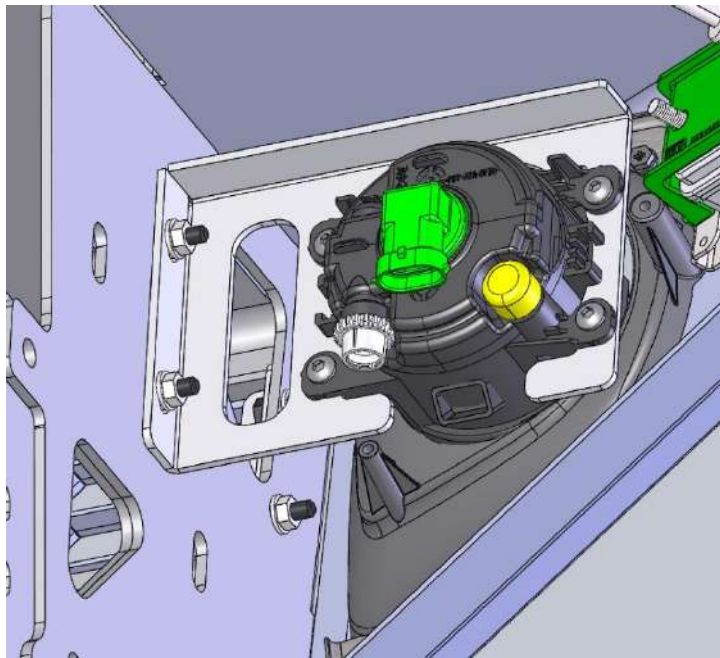

49. RH side shown. Fit original fog/DRL to rear face of bracket 3752138R using button head screws and M6 NYLOC nuts in fog housing kit. Fit bracket to bar using M6 x 20 black bolts, M6 flat washers and M6 flange nuts. Adjust so light is sitting central in housing and tighten fasteners.



M6 - 7 Nm.

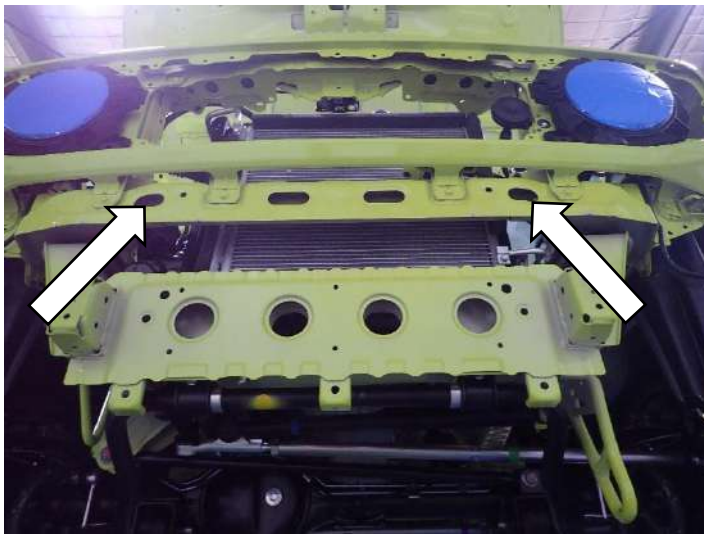

50. The headlight washer feed hose will now have to be routed before bar is installed. Remember to keep the plug fitting on the LH side. Shown by arrows feed tube through LH side hole in panel and out of RH side hole in panel. Plug fitting back into vehicle hose when done.



51. Fit plastic air dam back to vehicle.



52. Fit grille back to vehicle making sure to plug indicators back in.



53. Re fit intake hose back to vehicle.

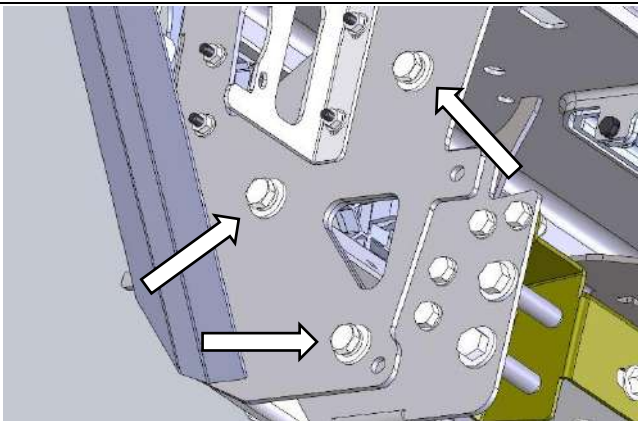

54. With the help of another person place the bar onto chassis mounts making sure the vehicle mounts sit on the inside face of the bar mounts. Align the three holes as shown and secure loosely with M10 SEMS bolts and M10 flange nuts. Hint: Access to the flange nuts can be obtained by opening the grille doors.



55. Align bar so the rear face lines up with the wheel arch. Raise the bar up to a minimum 5mm away from the bottom of the flared guard as shown. Tighten all bolts when satisfied.

56. Re-fit washer jets to bar and ensure lines are connected.



M10 - 44 Nm.



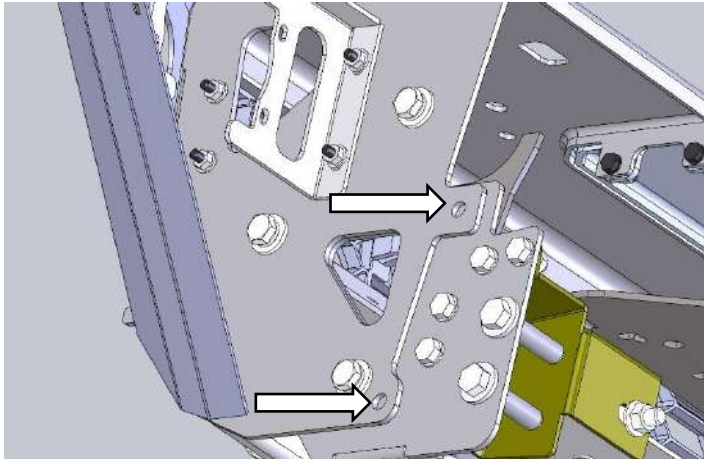



57. Using M10 holes as a guide in bar drill pinning holes out to 10mm. Paint holes and secure using M10 SEMS bolts and M10 flange nuts.

58. If fitting Roller fairlead do so now.

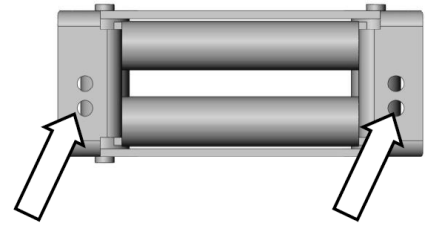
**NOTE: Winch Roller Fairlead must be drilled to 25mm offset if not already done so.**



 M10 - 44 Nm.

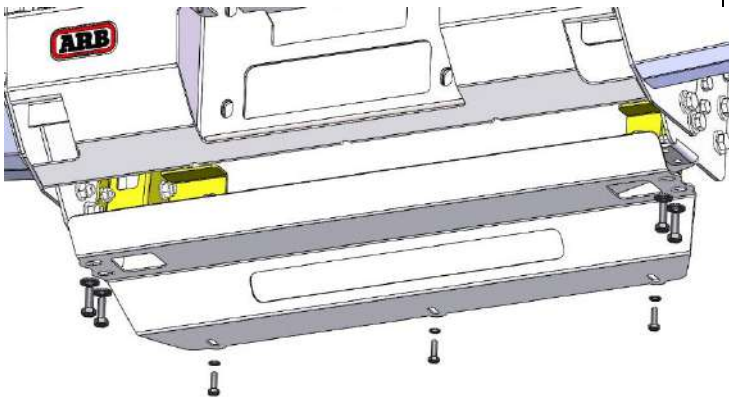

59. Fit splash guard to bar using four black M8 x 25 bolts and black M8 flat washers. Ensure bolts go through chassis cradle and chassis mount. Secure at top with M8 flange nuts. Secure rear section to vehicle using three black M6 x 20 bolts and flat washers. Tighten when complete.

 M8 - 22 Nm.

 M6 - 7 Nm.

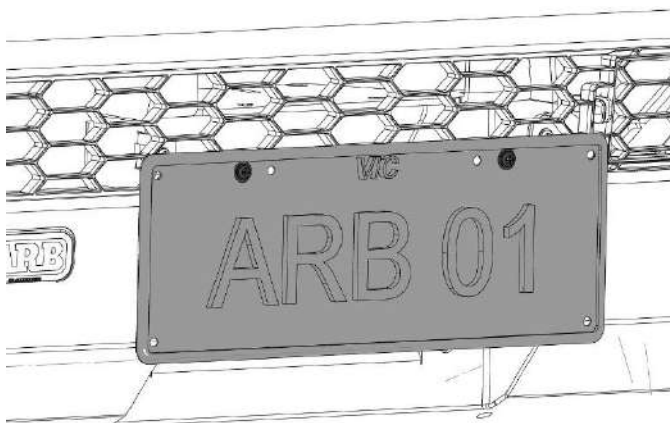

60. Fit the 2 larger plastic grommets into the license plate bracket. Attach the license plate to the bracket using 2 self-tapping, Philips head screws.

**Note: This step applies to both the fixed and folding license plate brackets.**



61. From just below the lower inner guard body mount clip mark a line horizontally across. Using a cutting tool carefully cut the inner guard trying to achieve as straight a cut as possible. De-burr plastics. Place outer lip of plastic behind wing lip of bar. Image shown without bar for clarity.



62. Secure top of inner guard to flare using screws removed earlier.

**NOTICE: ONCE SUMMIT BAR IS FITTED:**

- ◆ Ensure all bolts are tensioned correctly.
- ◆ All wiring is clear of sharp edges or moving surfaces and secured properly.
- ◆ Piping is secured well away from sharp or moving components.
- ◆ Check operation of winch, if fitted.
- ◆ Check all wiring and connections to turn signal lamps, sensors, headlamp washers etc. are functioning correctly.

**FITTED PRODUCT**

